

CONE CRUSHERS

XC-1100 / XC-1400 / XC-1500 / XC-1600

- All bronze bushing design.
- Easy crusher setting changes.
- Full operation from a remote location.
- Different liner styles to suit your crushing needs.

CLEMRO

© 05.2015 / Clemro Western Ltd.

P/1

SPECIFICATIONS

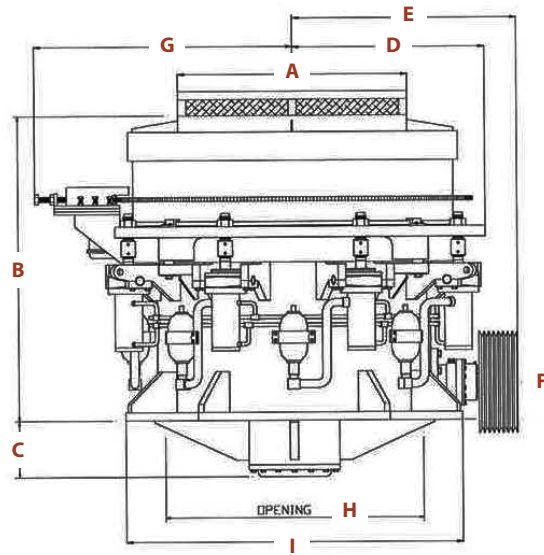

	XC-1100	XC-1400	XC-1500	XC-1600
	Length inch (mm)	Length inch (mm)	Length inch (mm)	Length inch (mm)
A	44.0" (1,117)	56.0" (1,422)	60.75" (1,543)	66.75" (1,695)
B	64.25" (1,631)	75.0" (1,905)	84.75" (2,152)	84.75" (2,152)
C	11.5" (292)	14.0" (355)	17.5" (444)	17.5" (444)
D	40.25" (1,022)	46.75" (1,187)	61.5" (1,562)	64.5" (1,638)
E	53.0" (1,346)	62.0" (1,574)	65.5" (1,663)	68.5" (1,739)
F	7.75" (196)	9.125" (233)	10.0" (254)	10.0" (254)
G	4.75" (120)	63.0" (1,600)	66.5" (1,689)	69.5" (1,765)
H	51.5" (1,308)	63.0" (1,600)	72.0" (1,828)	78.0" (1,981)
I	68.0" (1,727)	82.0" (2,082)	90.0" (2,286)	96.0" (2,438)

MODEL	CONE HEAD DIAMETER inch (mm)	MAX. FEED MEDIUM inch (mm)	MAX. FEED COARSE inch (mm)	MIN. CLOSE SIDE SIZE <i>MEDIUM</i> inch (mm)	MIN. CLOSE SIDE SIZE <i>COARSE</i> inch (mm)	HORSEPOWER HP (kw)
XC-1100	40.0" (1,016)	6.0" (152)	8.0" (203)	0.375" (9.5)	0.5" (12.7)	200 (149)
XC-1400	51.0" (1,295)	8.0" (203)	10.0" (254)	0.5" (12.7)	0.625" (15.8)	300 (223)
XC-1500	57.0" (1,447)	10.0" (254)	12.0" (304)	0.625" (15.8)	0.75" (19.0)	400 (298)
XC-1600	63.0" (1,600)	10.0" (254)	12.0" (304)	0.625" (15.8)	0.75" (19.0)	500 (372)

CLEMRO

PHOTO GALLERY

